

TB 9-6625-2157-24

CHANGE 1

DEPARTMENT OF THE ARMY TECHNICAL BULLETIN

CALIBRATION PROCEDURE FOR PULSE GENERATOR SG-366A/U (KAY, MODEL 5070B)

Headquarters, Department of the Army, Washington, DC
18 November 2008

Distribution Statement A: Approved for public release; distribution is unlimited.

TB 9-6625-2157-24, 29 January 2008, is changed as follows:

1. Remove old pages and insert new pages as indicated below. New or changed material is indicated by a vertical bar in the margin of the page.

Remove Pages
3 and 4

Insert Pages
3 and 4

2. File this change sheet in front of the publication for reference purposes.

By Order of the Secretary of the Army:

GEORGE W. CASEY, JR.
General, United States Army
Chief of Staff

Official

JOYCE E. MORROW
Administrative Assistant to the
Secretary of the Army

0826208

Distribution: To be distributed in accordance with IDN 343071, requirements for calibration procedure TB 9-6625-2157-24.

*TB 9-6625-2157-24

DEPARTMENT OF THE ARMY TECHNICAL BULLETIN

CALIBRATION PROCEDURE FOR PULSE GENERATOR SG-366A/U (KAY, MODEL 5070B)

Headquarters, Department of the Army, Washington, DC
29 January 2008

Distribution Statement A: Approved for public release, distribution is unlimited.

REPORTING OF ERRORS AND RECOMMENDING IMPROVEMENTS

You can improve this manual. If you find any mistakes or if you know of a way to improve these procedures, please let us know. Mail your letter or DA Form 2028 (Recommended Changes to Publications and Blank Forms) directly to: Commander, U.S. Army Aviation and Missile Command, ATTN: AMSAM-MMC-MA-NP, Redstone Arsenal, AL 35898-5000. A reply will be furnished to you. You may also send in your comments electronically to our E-mail address: 2028@redstone.army.mil or by fax 256-842-6546/DSN 788-6546. For the World Wide Web use: <https://amcom2028.redstone.army.mil>. Instructions for sending an electronic 2028 can be found at the back of this manual.

SECTION		Paragraph	Page
	I. IDENTIFICATION AND DESCRIPTION		
	Test instrument identification	1	2
	Forms, records, and reports.....	2	2
	Calibration description	3	2
	II. EQUIPMENT REQUIREMENTS		
	Equipment required	4	3
	Accessories required.....	5	3
	III. CALIBRATION PROCESS		
	Preliminary instructions.....	6	3
	Equipment setup	7	4
	Frequency	8	4
	Pulse rate	9	6
	Pulse width	10	7
	Output amplitude.....	11	7
	Rise and fall time	12	8
	Meter	13	8
	Power supply (version A)	14	9
	Power supply (version B)	15	9
	Final procedure	16	10

*This bulletin supersedes TB 9-6625-2157-35, dated 16 August 1985, including all changes.

**SECTION I
IDENTIFICATION AND DESCRIPTION**

1. Test Instrument Identification. This bulletin provides instructions for the calibration of Pulse Generator SG-366A/U (Kay, Model 5070B). The manufacturer's manual was used as the prime data source in compiling these instructions. The equipment being calibrated will be referred to as the TI (test instrument) throughout this bulletin.

a. Model Variations. There are two versions of SG-366A/U. The adjustments for version A are located on top view of the chassis. Version B and model 5070B are the same for calibration purposes, and adjustments are located on both top and bottom views. Some early models of model 5070B show different adjustment references for the same locations. These reference designations are not shown on the figures. Some adjustments for version B are located on the power supply assembly but are not related to the power supply function. Where adjustment locations are the same for both versions, they will be shown on version A, figure 1.

b. Time and Technique. The time required for this calibration is approximately 3 hours, using the dc and low frequency technique.

2. Forms, Records, and Reports

a. Forms, records and reports required for calibration personnel at all levels are prescribed by TB 750-25.

b. Adjustments to be reported are designated (R) at the end of the sentence in which they appear. When adjustments are in tables, the (R) follows the designated adjustment. Report only those adjustments made and designated with (R).

3. Calibration Description. TI parameters and performance specifications which pertain to this calibration are listed in table 1.

Table 1. Calibration Description

Test instrument parameters	Performance specifications
Power requirements	117 V ac $\pm 10\%$, 50 to 60 Hz
Frequency	Range: 10 to 120 MHz Accuracy: $\pm 1\%$
Output amplitude: Cw Pulsed RF Video pulse	0.5 V rms into 50 Ω 0.5 V into 50 Ω 3 V peak into 50 Ω
Rise and fall times: Video pulse Pulsed RF Pulse rate Pulse width	< 20 ns < 10 ns < 50 to > 5000 pps < 100 ns to > 100 μ s

SECTION II EQUIPMENT REQUIREMENTS

4. Equipment Required. Table 2 identifies the specific equipment to be used in this calibration procedure. This equipment is issued with Secondary Transfer Calibration Standards Set AN/GSM-286, AN/GSM-287 and AN/GSM-705. Alternate items may be used by the calibrating activity when the equipment listed in table 2 is not available. The items selected must be verified to perform satisfactorily prior to use and must bear evidence of current calibration. The equipment must meet or exceed the minimum use specifications listed in table 2. The accuracies listed in table 2 provide a four-to-one ratio between the standard and TI. Where the four-to-one ratio cannot be met, the actual accuracy of the equipment selected is shown in parenthesis.

5. Accessories Required. The accessories required for this calibration are common usage accessories issued as indicated in paragraph 4 above and are not listed in this calibration procedure. The following peculiar accessory is also required for this calibration: Semiconductor device (coaxial crystal detector) Agilent, Model 423AOPT03 (423AOPT03).

Table 2. Minimum Specifications of Equipment Required

Common name	Minimum use specifications	Manufacturer and model (part number)
AUTOTRANSFORMER	Range: 105 to 125 V ac Accuracy: $\pm 1\%$	Ridge, Model 9020A (9020A)
FREQUENCY COUNTER	Range: 50 Hz to 121.2 MHz Accuracy: 0.25%	Fluke, Model PM6681/656 (PM6681/656)
MULTIMETER	Range: 9.5 to 20.5 V Accuracy: $\pm 0.6\%$	Agilent, Model 3458A (3458A)
OSCILLOSCOPE	Range: 1.05 to 6 V p-p Accuracy: $\pm 3\%$ Risetime: < 10 ns	Agilent, OS-303/G (OS-303/G)

SECTION III CALIBRATION PROCESS

6. Preliminary Instructions

a. The instructions outlined in paragraphs 6 and 7 are preparatory to the calibration process. Personnel should become familiar with the entire bulletin before beginning the calibration.

b. Items of equipment used in this procedure are referenced within the text by common name as listed in table 2.

c. Unless otherwise specified, verify the result of each test and, whenever the test requirement is not met, take corrective action before continuing with the calibration. Adjustments required to calibrate the TI are included in this procedure. Additional maintenance information is contained in the manufacturer's manual for this TI.

d. When indications specified in paragraphs 7 through 13 are not within tolerance, perform the power supply check prior to making adjustments. After adjustments are made, repeat paragraphs **7** through **13**. Do not perform power supply check if all other parameters are within tolerance.

e. Unless otherwise specified, all controls and control settings refer to the TI.

WARNING

HIGH VOLTAGE is used or exposed during the performance of this calibration. DEATH ON CONTACT may result if personnel fail to observe safety precautions. REDUCE OUTPUT(S) to minimum after each step with the performance check where applicable.

7. Equipment Setup

a. Position controls as listed in (1) through (6) below:

- (1) Frequency control outer dial to **10-16** and inner dial to **10**.
- (2) Function switch to **OFF**.
- (3) **RF OR PULSE LEVEL** control fully ccw.
- (4) **PULSE RATE** switch to **50-500**.
- (5) **PULSE WIDTH** switch **1-10**.
- (6) All **ATTENUATOR (DB)** switches to off (down).

b. If TI output meter does not indicate zero, adjust to zero, using adjustment screw located on top of meter behind front panel.

c. Connect TI to autotransformer.

d. Connect autotransformer to 115 V ac source and adjust for 117 V output.

e. Set function switch to **CW** and allow at least 15 minutes for equipment to reach operating temperature.

8. Frequency

a. Performance Check

(1) Connect frequency counter to **PULSE OR RF OUT**.

(2) Adjust **RF OR PULSE LEVEL** control for stable indication on frequency counter. If frequency counter does not indicate between 9.9 and 10.1 MHz, perform **b** below.

(3) Repeat technique of (2) above at frequency range positions listed in table 3. If frequency counter does not indicate within limits specified, perform **b** below.

Table 3. Frequency

Test instrument frequency control		Frequency counter indications (MHz)	
Outer Dial	Inner Dial	Min	Max
10-16	13	12.87	13.13
10-16	16	15.84	16.16
16-25	16	15.84	16.16
16-25	20	19.80	20.20
16-25	25	24.75	25.25
25-40	25	24.75	25.25
25-40	35	34.65	35.35
25-40	40	39.60	40.40
40-65	40	39.60	40.40
40-65	55	54.45	55.55
40-65	65	64.35	65.65
65-120	65	64.35	65.65
65-120	100	99.0	101.0
65-120	120	118.8	121.2

b. Adjustments

- (1) Adjust appropriate tuning slugs (fig. 1) as listed in (a) through (e) below:
 - (a) L6 for 10-16 range.
 - (b) L1 for 16-25 range.
 - (c) L2 for 25-40 range.
 - (d) L3 for 40-65 range.
 - (e) L4 for 65-120 range. See second note below.

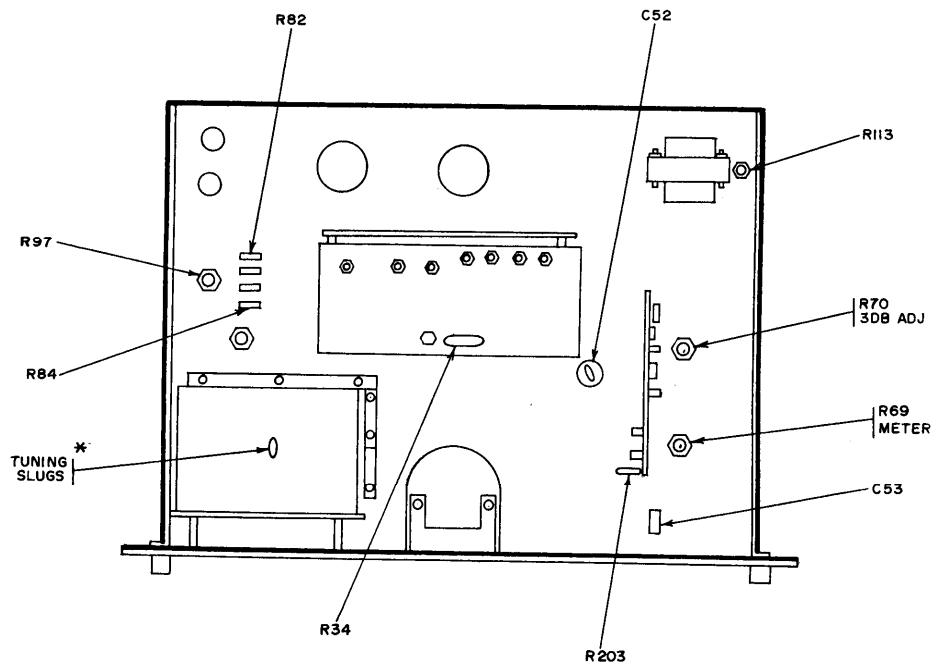

* SOME MODELS REQUIRE REMOVAL OF OSCILLATOR COVER TO GAIN ACCESS TO TUNING SLUGS. SOME MODELS HAVE NO COVER.

Figure 1. Test instrument, version A - top view.

NOTE

The tuning slugs have a double threaded adjustment. The first section turns a short way before picking up the next section and works in the same manner in both in and out adjusting.

NOTE

On some models the 65-120 range has no tuning slug. Adjustment is accomplished by changing coil spacing. Compressing the coil lowers frequency. Spreading coil raises frequency.

9. Pulse Rate

a. Performance Check

(1) Position controls as listed in (a) through (e) below:

- (a) Function switch to + **VIDEO PULSE**.
- (b) **RF OR PULSE LEVEL** control fully cw.
- (c) **PULSE WIDTH** switch to **1-10**.
- (d) **PULSE RATE** switch to **50-500**.
- (e) **WIDTH ADJ** control fully cw.

(2) Turn **RATE ADJ** control fully ccw. If frequency counter does not indicate 50 Hz or less, perform **b** below.

(3) Set **PULSE RATE** switch to **500-5KC** and **RATE ADJ** control fully cw. If frequency counter does not indicate 5 kHz or more, perform **b** below.

b. Adjustments. Adjust R203 (fig. 1 or 2) for 5 kHz indication on frequency counter (R).

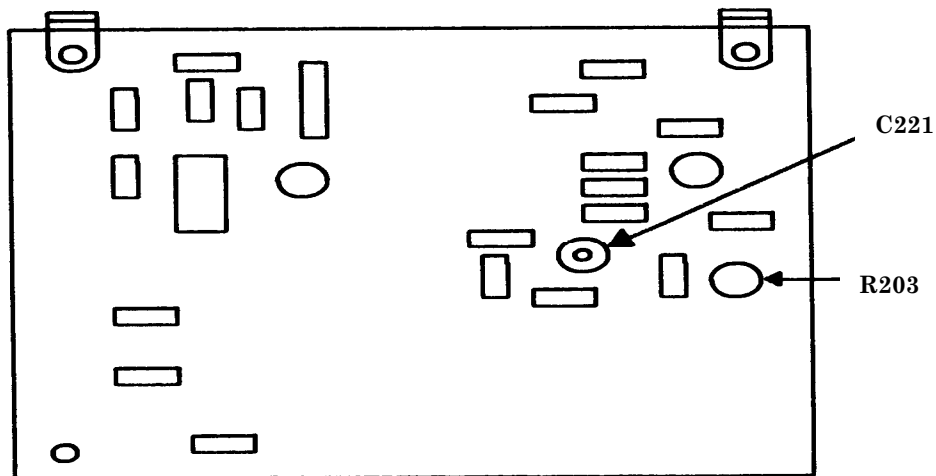

Figure 2. Pulse generator assembly - adjustment locations.

10. Pulse Width

a. Performance Check

- (1) Set **PULSE WIDTH** switch to **.1-1** and **WIDTH ADJ** control fully cw.
- (2) Measure pulse width on frequency counter. If pulse width is not 0.1 μs or less, perform **b** below.
- (3) Set **PULSE WIDTH** switch to **10-100** and **WIDTH ADJ** control fully cw.
- (4) Measure pulse width. If frequency counter does not indicate 100 μs or more, perform **b** below.

b. Adjustments. Adjust C53 (fig. 1) for best in-tolerance condition in **a** (2) and (4) above (R).

11. Output Amplitude

a. Performance Check

- (1) Connect oscilloscope to **PULSE OR RF OUT** using 50 Ω termination.

NOTE

Do not use termination if using oscilloscope with 50 Ω input.

- (2) Position controls as listed in (a) through (d) below:
 - (a) Function switch to **CW**.
 - (b) **RF OR PULSE LEVEL** control fully cw.
 - (c) **PULSE WIDTH** switch to **1-10**.
 - (d) **WIDTH ADJ** control fully cw.
- (3) Measure pulse amplitude. If oscilloscope does not indicate at least 1.5 V p-p, perform **b** (1) below.
- (4) Set function switch to **PULSED RF**. Measure pulse amplitude. If oscilloscope does not indicate at least 1.5 V p-p, perform **b** (1) below.
- (5) Set function switch to **+ VIDEO PULSE**. If oscilloscope does not indicate at least 3 V peak, perform **b** (2) below.
- (6) Set function switch to **- VIDEO PULSE**. If oscilloscope does not indicate at least 3 V peak, perform **b** (3) below.

b. Adjustments

- (1) Adjust R97 (fig. 1) or R14 (fig. 3) until oscilloscope indicates at least 1.5 V p-p (R).
- (2) Adjust R84 (fig. 1) or R21 (fig. 3) until oscilloscope indicates at least 3 V peak (R).
- (3) Adjust R82 (fig. 1) or R23 (fig. 3) until oscilloscope indicates at least 3 V peak (R).

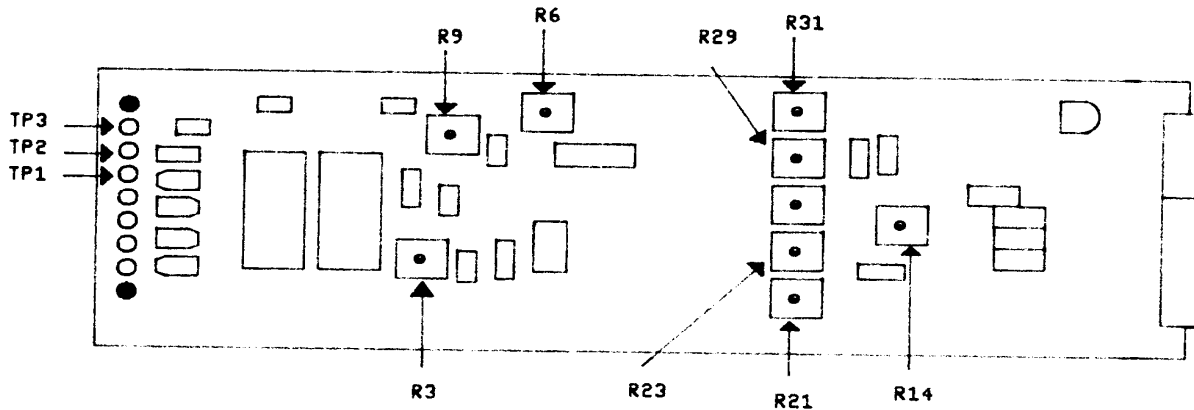

Note: Power supply assembly is located on bottom view of TI.

Figure 3. Power supply assembly - adjustment locations.

12. Rise and Fall Time

a. Performance Check

- (1) Connect **PULSE OR RF OUT** connector to oscilloscope using coaxial crystal detector and 50 Ω termination.
- (2) Set function switch to **PULSED RF**.
- (3) Measure rise and fall times of pulse. If rise or fall times are not 10 ns or less, perform **b** (1) below.
- (4) If spikes are present, perform **b** (2) below.
- (5) Remove coaxial crystal detector.
- (6) Set function switch to **+ VIDEO PULSE**.
- (7) Measure rise and fall times. Rise and fall times will be 20 ns or less.

b. Adjustments

- (1) Adjust C52 (fig. 1) or C221 (fig. 2) for best rise and fall times ≤ 10 ns (R).
- (2) Adjust R34 (fig. 1) for minimum spikes (R).

13. Meter

a. Performance Check

- (1) Set function switch to **CW**.
- (2) Set frequency control outer dial to **10-16** and inner dial to **10**.

(3) Adjust **RF OR PULSE LEVEL** control until TI meter indicates 0.5 V. If oscilloscope does not indicate at least 1.5 V p-p, perform **b** (1) and (2) below.

(4) Adjust **RF OR PULSE LEVEL** control until TI meter indicates -3 dB. If oscilloscope does not indicate 1.05 V p-p or less, perform **b** (3) through (5) below.

b. Adjustments

(1) Adjust **RF OR PULSE LEVEL** control until oscilloscope indicates 1.5 V p-p.

(2) Adjust R69 METER (fig. 1) or R31 (fig. 3) until TI meter indicates 0.5 V (R).

(3) Adjust **RF OR PULSE LEVEL** control until oscilloscope indicates 1.05 V p-p.

(4) Adjust R70 3dB ADJ (fig. 1) or R29 (fig. 3) until TI meter indicates -3 dB (R).

(5) Repeat **a** (3) and (4) above.

14. Power Supply (Version A)

NOTE

Do not perform power supply check if all other parameters are within tolerance.

a. Performance Check. Connect multimeter between plus side of C70 (fig. 4) and ground. If multimeter does not indicate between 19.5 and 20.5 V dc, perform **b** below.

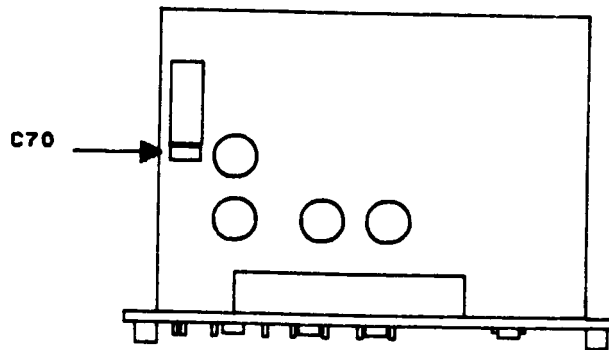

Figure 4. Test instrument, version A bottom view.

b. Adjustments. Adjust R113 (fig. 1) until multimeter indicates 20.0 V dc (R).

15. Power Supply (Version B)

NOTE

Do not perform power supply check if all other parameters are within tolerance.

a. Performance Check

(1) Connect multimeter between TP1 (fig. 3) and ground. If multimeter does not indicate between 19.5 and 20.5 V dc, perform **b** (1) below.

(2) Disconnect lead from TP1 and connect to TP2 (fig. 3). If multimeter does not indicate between 10.5 and 12.5 V dc, perform **b** (2) below.

(3) Disconnect lead from TP2 and connect to TP3 (fig. 3). If multimeter does not indicate between -9.5 and -11.5 V dc, perform **b** (3) below.

b. Adjustments

(1) Adjust R9 (fig. 3) until multimeter indicates 20.0 V dc (R).

(2) Adjust R3 (fig. 3) until multimeter indicates 11.0 V dc (R).

(3) Adjust R6 (fig. 3) until multimeter indicates -11.0 V dc (R).

16. Final Procedure

a. Deenergize and disconnect all equipment.

b. Annotate and affix DA label/form in accordance with TB 750-25.

By Order of the Secretary of the Army:

Official:

JOYCE E. MORROW
*Administrative Assistant to the
Secretary of the Army*

GEORGE W. CASEY, JR.
*General, United States Army
Chief of Staff*

0734607

Distribution:

To be distributed in accordance with the initial distribution number (IDN) 343071, requirements for calibration procedure TB 9-6625-2157-24.

Instructions for Submitting an Electronic 2028

The following format must be used if submitting an electronic 2028. The subject line must be exactly the same and all fields must be included; however, only the following fields are mandatory: 1, 3, 4, 5, 6, 7, 8, 9, 10, 13, 15, 16, 17, and 27.

From: "Whomever" whomever@redstone.army.mil
To: <2028@redstone.army.mil

Subject: DA Form 2028

1. **From:** Joe Smith
2. **Unit:** home
3. **Address:** 4300 Park
4. **City:** Hometown
5. **St:** MO
6. **Zip:** 77777
7. **Date Sent:** 19-OCT -93
8. **Pub no:** 55-2840-229-23
9. **Pub Title:** TM
10. **Publication Date:** 04-JUL-85
11. **Change Number:** 7
12. **Submitter Rank:** MSG
13. **Submitter FName:** Joe
14. **Submitter MName:** T
15. **Submitter LName:** Smith
16. **Submitter Phone:** 123-123-1234
17. **Problem:** 1
18. **Page:** 2
19. **Paragraph:** 3
20. **Line:** 4
21. **NSN:** 5
22. **Reference:** 6
23. **Figure:** 7
24. **Table:** 8
25. **Item:** 9
26. **Total:** 123
27. **Text**

This is the text for the problem below line 27.

